

SELMACHTM
MACHINERY

Making Metal Work



XTM Tube Laser

The Morgan Rushworth XTM range of tube laser cutting machines are especially applicable for round, square, rectangular, oval and waist round tubes.

Manufactured with the world's leading fibre laser resonator and electronic components to ensure superior stability. The high clamping bed feature provides outstanding rigidity whilst performing at high speed and acceleration, taking your tube laser cutting to the next level.

**WATCH THIS
MACHINE IN
ACTION**





SUPERIOR TUBE CUTTING QUALITY



OPTIONAL MAGAZINE LOADING SYSTEM



CNC CONTROL AT YOUR FINGER TIPS

- Equipped with new multi-touch CNC Controller
- 5000mm-8000mm unrestricted mixed row automatic intelligent processing
- Seamlessly docked with the intelligent manufacturing factory
- MESS cloud data management system

LANTEK FLEX3D

- Easy, Flexible Design
- Accurate, suitable for a wide range of pipe types
- Optimising and Cutting of Tubes
- CNC Simulation and Generation

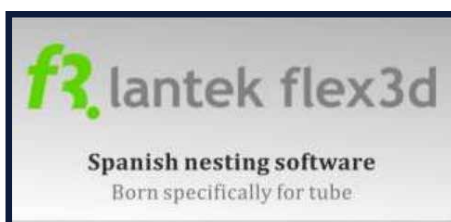

Machine Features

- High performance Max Photonics Laser Source
- Fibre optic beam delivery system
- RayTools Autofocus Laser Cutting Head
- High strength, rigid gantry design to ensure high accuracy and allow high acceleration
- High precision class alpha rack and pinion drive motion system
- Applicable tube types : Round tube, square tube, rectangular tube, oval tube, D-shaped steel, T-shaped steel, H-shaped steel, channel steel, angle steel, etc.
- CE compliant complete machine enclosure and light barrier system
- Lantek Flex3d CNC Laser Control and Software

Optional Equipment

- OuXTMeed Support - 4m / 6m
- Precitec ProCutter Head
- 3D Bevel Cutting Torch
- Optional Magazine Loading system
- Conveyor ouXTMeed
- Weld Seam Detection
- UPS: Uninterruptible Power Supply
- Filtration & Extraction

Lantek Flex3d Supporting Various Pipes

Standard pipes :
Equal diameter pipes such as round, square, OB-type, D-type, triangular, oval etc.

Meanwhile, flex3d is equipped with profile cutting function modules to cut angle steel, channel and H-shaped steel, etc.

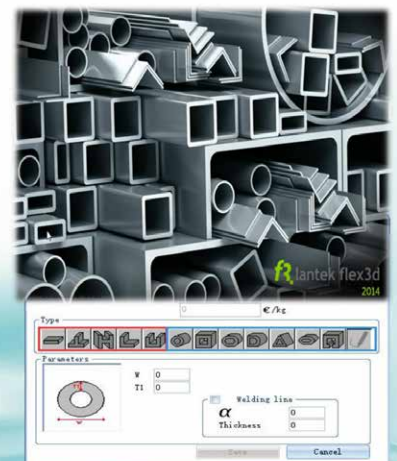



HIGH SPEED FULL STROKE CHUCK - UP TO 130 RPM

Tube Range Up to 235mm / 350mm



FULL SERVO DYNAMIC SUPPORT

Tube Range Up to 235mm / 350mm



INTELLIGENT AUTO LOADER

2.5T Ø20-200mm; 800 x 800 x 6200mm

3,500 - 6,200mm, unrestricted mixed-row automatic intelligent processing



AUTOMATED LASER CUTTING HEAD

2D (3D Laser Cutting Optional)

Auto Focus

High degree of automation and good performance



FLY CUTTING OF TUBE

Ultra-fast fly cutting, high precision and time saving.



SLAG REMOVAL

Ensures the inner wall of the pipe is clean, eliminating secondary cleaning processes.



DUST REMOVAL

Tail chuck dust removal function to reduce environmental pollution and dust.



LONG PIPES & TUBES

Floating support specially designed for cutting long finished workpieces.

OPTIONAL EXTRAS

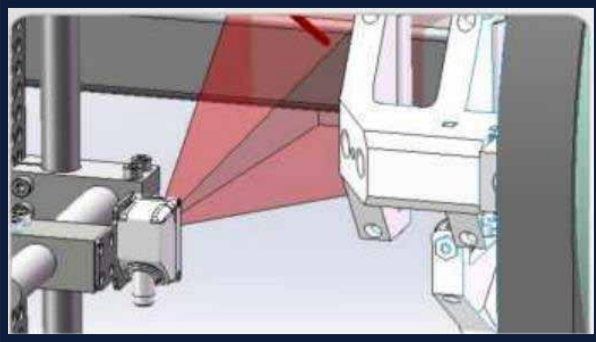

**KEYENCE VISUAL WELDING SEAM
DETECTION**

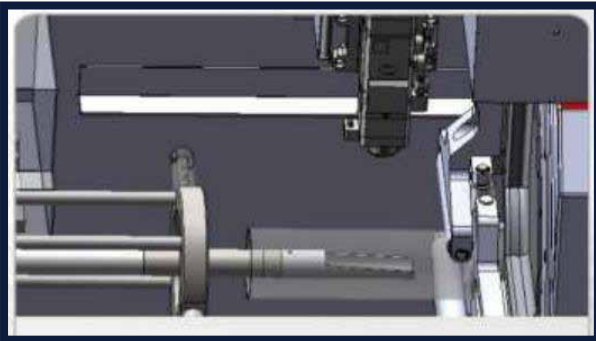

AUTOMATICAL DESLAGGING



3D BEVEL CUTTING (+45°)



**MES PRODUCTION MONITOR
SOFTWARE**

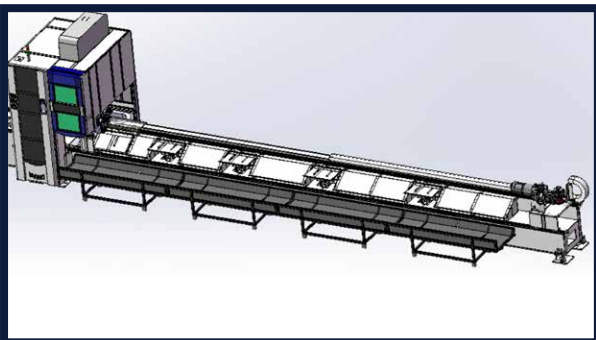

C3 CHUCK

CUTTING CAPACITIES

LASER SOURCE	kW	1.5	2.5	3	4	6
Cutting Capacity - Mild Steel	mm	14	20	22	25	25
Cutting Capacity - Stainless Steel	mm	6	10	12	12	20
Cutting Capacity - Aluminium	mm	5	8	10	12	16
Cutting Capacity - Brass	mm	5	8	8	12	14
Cutting Capacity - Copper	mm	4	6	6	6	10
Cutting Capacity - Galvanised Steel	mm	5	6	8	10	14

KEY COMPONENTS

COMPONENT	BRAND
Fibre Laser Source	Max Photonics
CNC Controller	Power Automation Higerman
CAM/CAD software Flex3D	Lantek
Servo motor and driver	Yaskawa
Rack and Pinion	YYC / J & T
Linear Guide	Hiwin
Laser Head	Raytools
Gas Proportional Valve	SMC
Reduction Gear Box	Innowelle
Chiller	Tong Fei
Rotate Chuck System	Morgan Rushworth
Automatic Support	Morgan Rushworth
Automatic Bundle Loader	Morgan Rushworth
Automatic Unloading	Morgan Rushworth
Electrical Components	Schneider
Welding Seam Visual Detection (Optional)	Keyence
C3 Chuck (Optional)	Morgan Rushworth

TECHNICAL SPECIFICATIONS

TABLE STOCK CODE		XTM6025 / XTM6025A	XTM8025 / XTM8025A	XTM6035 / XTM6035A	XTM8035 / XTM8035A
Laser Power	kW	1.5/2/3/4/6			
Tube Length	mm	6,000	8,000	6,000	8,000
Tube Diameter	mm	Round Ø : 20 - 235 Square : 20 x 20 - 235 x 235		Round Ø : 20 - 350 Square : 20 x 20 - 245 x 245	
Cutting Profiles (Standard)		Round, Square, Rectangular			
Cutting Profiles (Optional)		Angle, Channel, H-Shape, L-Shape, Steel Band, etc			
Weight of Single Tube	kg	250		530	
Positioning Speed	m/min	120		72	
Chuck Rotation Speed	rpm	130		75	
Axis Acceleration	G	1.2		0.6	
Positioning Accuracy	mm	±0.05		±0.05	
Repeat Positioning Accuracy	mm	±0.03		±0.03	
Length	mm	12,070	13,400	12,070	13,400
Width	mm	2,700		2,700	
Width (with Optional Magazine Loader)	mm	5,000		5,000	
Height	mm	2,300		2,300	
Weight	kg	8,000		9,000	
Weight (with Optional Magazine Loader)	kg	15,000		17,000	
OPTIONAL BUNDLE LOADING SYSTEM					
Bundle Size (Optional Bundle Loader)	mm	800 x 800 x 800		800 x 800 x 800	
Bundle Loading Weight	kg	2,500		2,500	





