



CNC Electric Pressbrakes

The Morgan Rushworth range of XPE servo electric press brakes are designed with a belt and pulley system, and the XPS range utilises a ball & screw system - providing low energy usage, high bending cycle times and high accuracy. The range spans from 1530mm x 40T machines up to 3100mm x 100T, with all models equipped with the ESA VIS-875W 2D CNC touch screen controller.

The combination of consistent pressure across the beam from the pulley system, high positioning accuracy of 0.01mm and the O frame design with virtually no flex results in a level of accuracy far higher than in conventional hydraulic machines. The side frames are fitted at each end of the machine meaning that the backgauge can be used for the full width of the machine to the maximum depth. The XPE and XPS Servo electric press brakes are far more reliable than hydraulic machines with no rams, seals, pumps, pipes etc resulting in less down time.



XPE 3100.100



XPS 1300.36

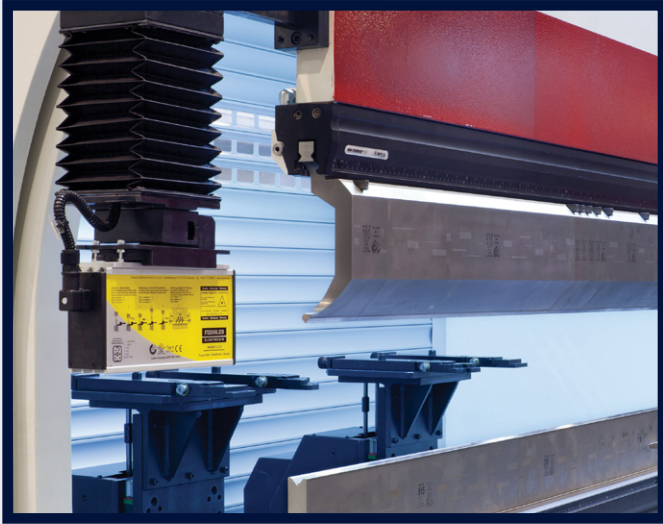

FRONT LASER PROTECTION SYSTEM

Machine Features

- ESA VIS-875W 2D CNC multi-axis CNC control with numerical and 2D graphical programming and 2D or 3D visualisation
- Control mounted on a height adjustable arm
- Fully synchronised CNC control of left and right upper beam cylinder position – Y1 + Y2 axis
- CNC control of back gauge depth – X axis
- CNC control of back gauge height – R axis
- AKAS laser tooling guards for enhanced ease of use
- High approach and return speeds for production bending
- Front support arms with brush table, adjustable on a linear rail
- Approximately 50% less energy use compared with hydraulic machines
- Approximately 30% faster cycle times
- Approximately 75% less servicing costs than hydraulic machines
- Green technology – no oil or hazardous waste affecting the environment

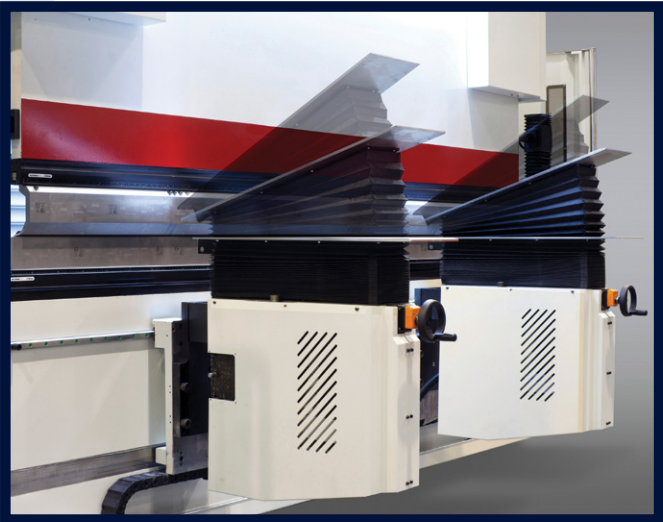

**SHEET FOLLOWER SUPPORT ARMS
(OPTIONAL)**

Optional Equipment

- Multi axis backgauges
- Hydraulic tool clamping
- Laser angle measuring system
- Sheet follower support arms
- Optional offline ESA Bend 3D Software with Control Viewer



QUICK RELEASE TOOL CLAMPING

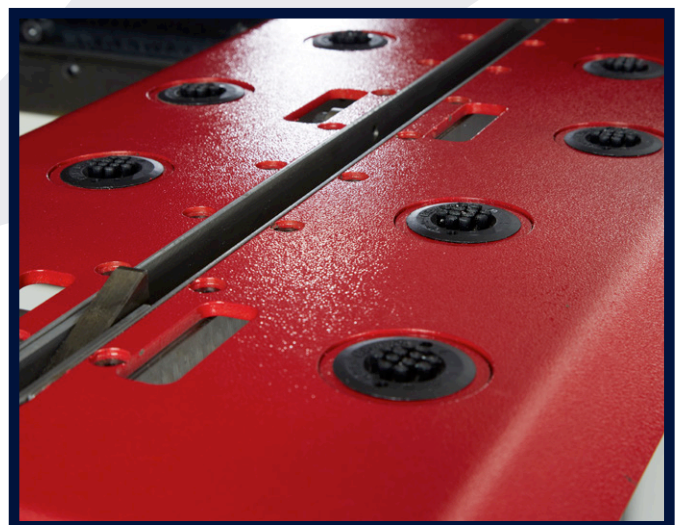

**FRONT SUPPORT ARMS
WITH BRUSH TABLE**

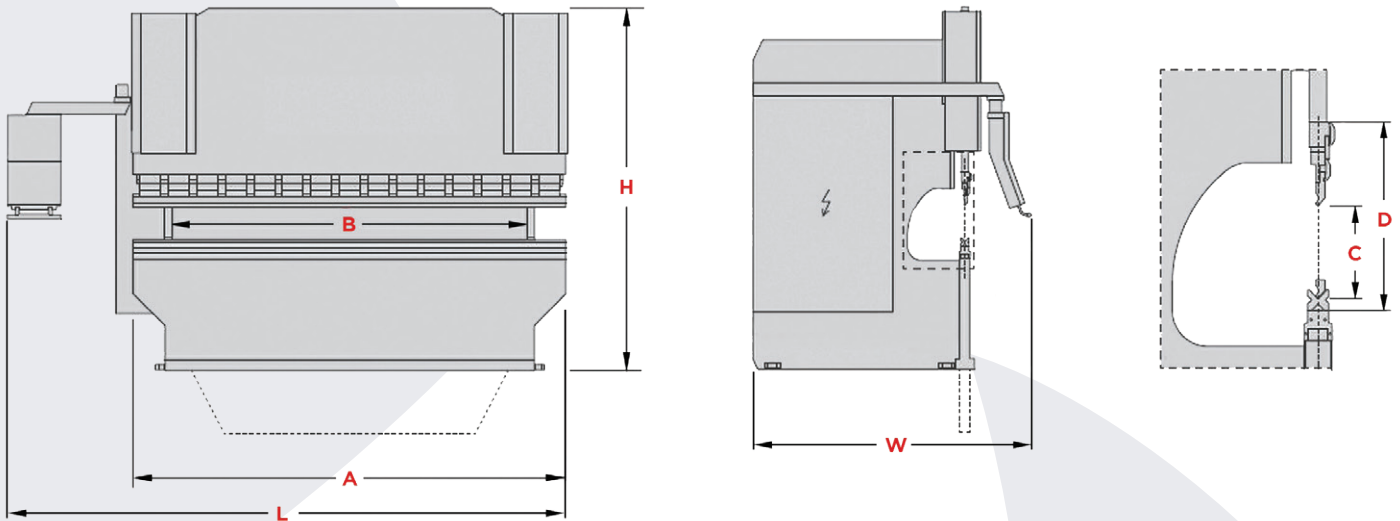

TECHNICAL SPECIFICATIONS

MODEL		XPE 1550.40	XPE 2050.50	XPR 2550.80	XPR 3100.100	XPS 900.20	XPS 1300.36
Mechanism		Belt & Pulley	Belt & Pulley	Belt & Pulley	Belt & Pulley	Ball Screw	Ball Screw
Bending Power	Tonne	40	50	80	100	20	36
Bending Length	(A) mm	1530	2040	2550	3050	900	960
Distance between columns	(B) mm					1020	1300
Y Approach Speed	mm/sec	170	150	90	75	150	150
Y Working Speed	mm/sec	10	10	10	10	10	10
Y Return Speed	mm/sec	170	150	90	75	150	150
Travel in X Axis	mm	500	500	750	750	750	750
Travel in R Axis	mm	150	150	250	250	160	160
No. of Back Gauge Fingers		2	2	2	2	2	2
No. of Sheet Support Arms		2	2	2	2	2	2
Motor Power	kw	11	11	11	11	3.8	10
Stroke	(C) mm	300	300	300	300	150	150
Daylight	(D) mm	660	660	660	660	340	340
Length	(L) mm	2660	3170	3680	4220	1650	2050
Width	(W) mm	1960	1960	1960	1960	1700	1700
Height	(H) mm	2900	2900	2900	2900	2350	2350
Weight	kg	4600	4850	6100	6500	3000	4350

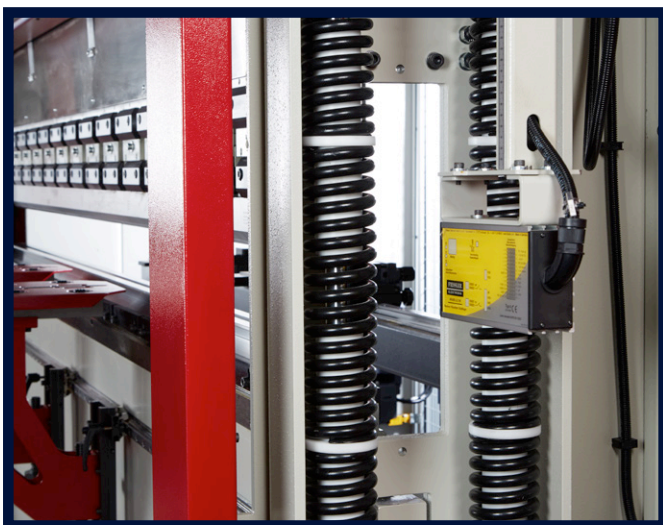

BALL & SCREW SYSTEM ON THE XPS

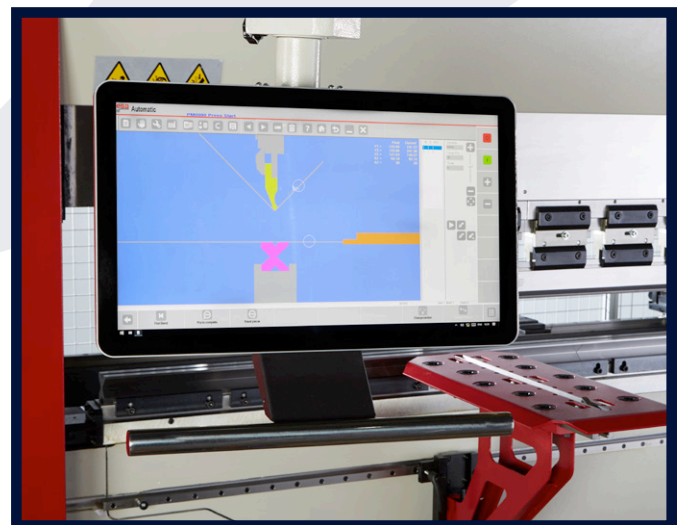

ESA 875 CONTROLLER