

2. MACHINE DESCRIPTION

2.1. Machine Identification

Trade Mark	Morgan Rushworth
Type	MECHANICAL GUILLOTINE SHEAR (NC Back Gauge)
Model	RGMS 1350-3 RGMS 1550-3 RGMS 2050-3

2.2. Machine Main Dimensions

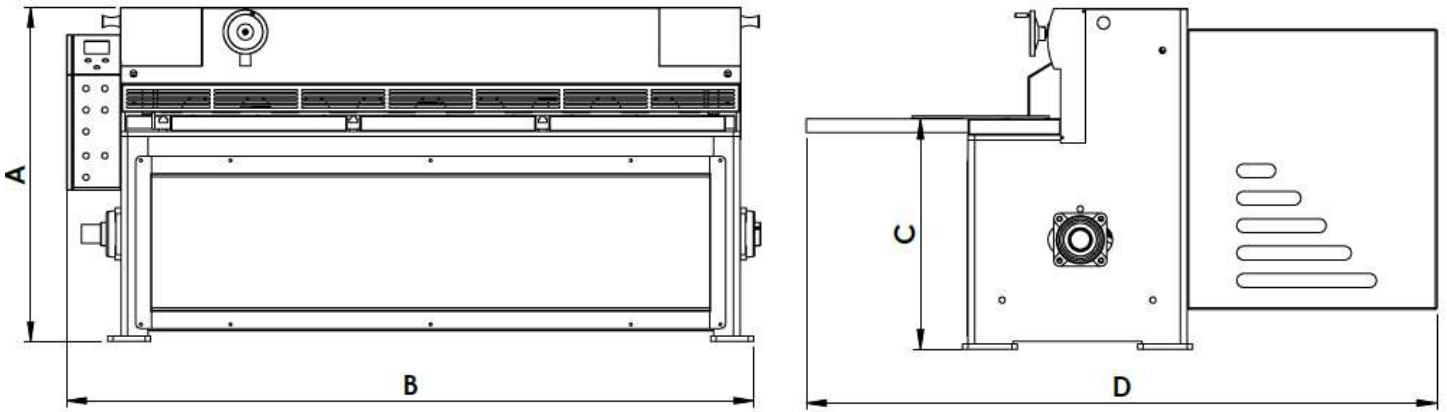

Model	A	B	C	D
RGMS 1350-3	1242mm	1855mm	840mm	2302mm
RGMS 1550-3	1242mm	2055mm	840mm	2302mm
RGMS 2050-3	1242mm	2555mm	840mm	2302mm

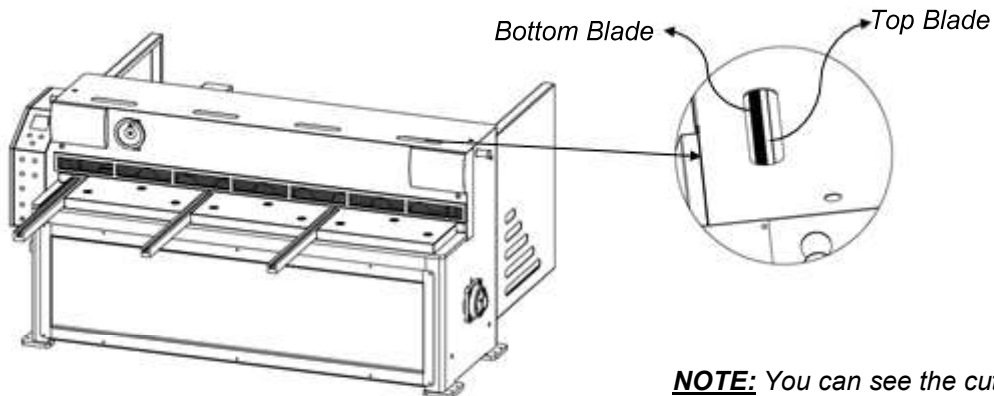

NOTE: You can see the cutting area through the window at the top.